

SEA3D420



Features

- High performance, low noise, affordable price, high speed and torque, excellent stability
- 16 selections of uniform angle and constant torque subdivisions, the max resolution up to 60000 steps/rev
- Adoption of 3-wires-control circuit greatly reduces noise and increases the rotation stability
- The max response frequency up to 200Kpps
- Once the pulse stops for more than 100ms, the coil current will be reduced to 20%~80% (set by STOP) automatically
- Bipolar constant current chopper control improves the output speed and power of the motor
- Optically isolated signal I / O
- Current range: 0.6A~4.2A / be divided into 16 grades
- Single power input, voltage range :AC110~220V (the optimal voltage is AC220V)
- Error Protection: ① Overheating ② Overcurrent ③ Low voltage
- Dimension: 178mm×118.5mm×68mm, Net weight: 1.25kg

Introduction

SEA3D420 is a microstep motor driver with uniform angle and constant torque subdivisions, voltage range is AC110~220V (the optimal voltage is AC220V), single power supply. It matches 3 phase hybrid stepper motors which rated current under 4.2A, external diameter 86mm~130mm, and outlets 3 or 6.

Bipolar constant current chopper control makes the motor run smoothly with lower noise and higher stability; The increase of the voltage greatly improves the drive capability and speed. The coil current will be automatically reduced to 20%~80% (set by STOP) once the pulse stops for more than 100ms, it reduces the heat of driver by 50%, reduces the heat of motor as well. Users can choose low speed high subdivision which up to 60000 steps/rev, it improves the precision, reduces the vibration and noise.

Applications

Carpentry engraving machine, Laser engraving machine, Labelling machine, Die bonder, Inkjet printer, Embroiderer, Dispenser, BGA repair machine, Laminating machine Wire-stripping machine, Winding machine, Hot-press machine, PCB drilling machine, Non-standard equipment, XYZ gauge, Connectors assemble machine, Medical equipments, Semiconductor Equipment, Blast furnace, etc.

Microstep Setting List

SK	F	E	D	C	B	A	9	8	7	6	5	4	3	2	1	0
Pulse/rev	400	500	600	800	1000	1200	2000	3000	4000	5000	6000	10000	12000	20000	30000	60000

DIP Switch Setting

DP1	OFF: accept external pulse signal ON: driver send 7.5KHz pulse, then the microstep should be set to be 2000-10000
DP2	OFF: pulse signal+direction signal control ON: clockwise pulse+counter clockwise pulse control

Running Current Setting

1. STOP/Im is stable state current adjuster, it can be set to 20%~80% of the normal output current (Adjusting it clockwise will increase the current and counterclockwise decrease current)
2. RUN/Im is normal running current adjuster (please check the details as follows)

RUN/Im	0	1	2	3	4	5	6	7
Im(A)	0.6	0.8	1.1	1.4	1.6	1.9	2.1	2.3
RUN/Im	8	9	A	B	C	D	E	F
Im(A)	2.6	2.9	3.0	3.2	3.5	3.7	4.0	4.2

Input signal timing diagram

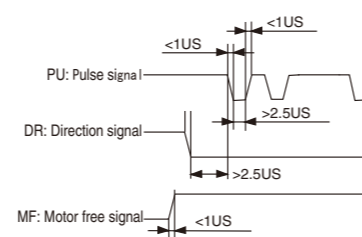

Installation dimensions

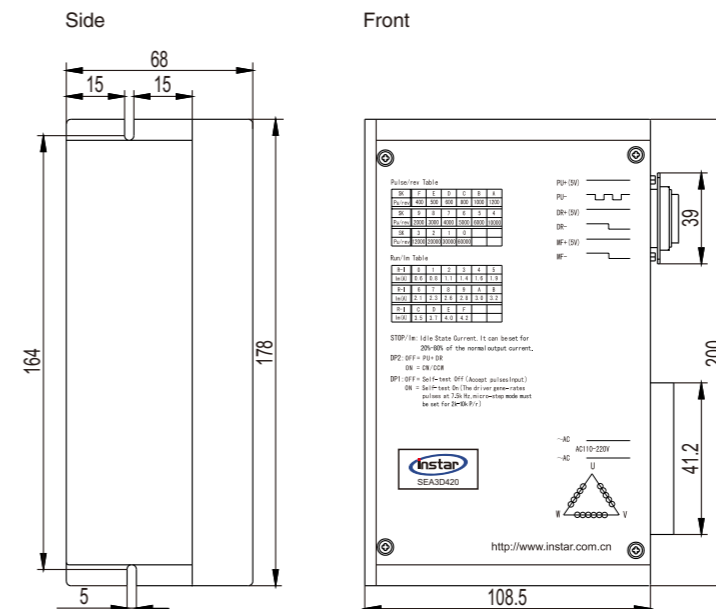

Driver Connection

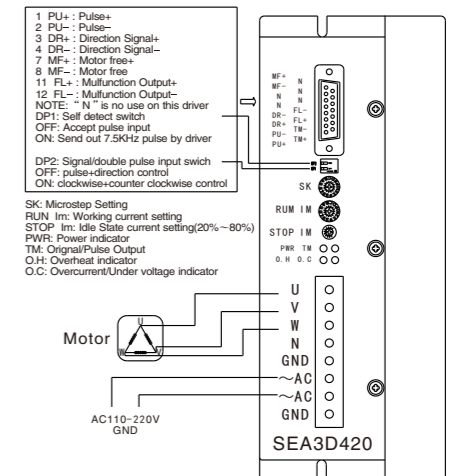

Terminal Assignment

Mark	Function	Instruction
POWER	Power indicator	Power on, the green indicator normally on.
TM	Working indicator light	When the pulse frequency is low, the green indicator flashes, when the pulse frequency is high, the green indicator normally on.
O.H	Overheat indicator	The Temperature rise exceeds 70 °C, the red indicator normally on.
O.C	Overcurrent / Low voltage indicator	The current exceeds rated value or the voltage is lower than rated value, the red indicator normally on.
Im	Phase current setting adjuster	Set the phase current, clockwise it increases, anticlockwise it decreases.
PU+	Input signal positive side	For changing the direction,input resistance is 220 Ω. Requires: low level +0V~+0.5V, high level+4V~+5V, pulse width >2.5 μs
PU-	DP2=OFF, PU is pulse signal DP2=ON,PU is clockwise pulse signal	When the falling edge is valid, the motor moves a step as the pulse become lower, input resistance is 220Ω. Requires: low level +0V~+0.5V, high level +4V~+5V, pulse width >2.5 μs.
DR+	Input signal positive side	For changing the direction,input resistance is 220 Ω. Requires: low level +0V~+0.5V, high level+4V~+5V, pulse width >2.5 μs
DR-	DP2=OFF, direction control signal DP2=ON, counter clockwise pulse signal	Pulse signal power supply should in the range of +5V~+24V, if higher than +5V needs to add a resistor.
MF+	Input signal positive side	Pulse signal power supply should in the range of +5V~+24V, if higher than +5V needs to add a resistor.
MF-	Motor free signal	When the low electrical level is valid, it cuts off the motor current, the driver stops working and motor will be in a free state.
TM+	Origin input signal positive side	The signal is valid when the motor pass electrical origin.
TM-	Origin output signal negative side	TM+ connects resistor, TM- connects GND, the max output current is 50mA, the max voltage is 50V.
RDY+	Driver ready signal positive side	Pulse signal power supply should in the range of +5V~+24V, if higher than +5V needs to add a resistor.
RDY-	Driver ready signal negative side	It's valid when the driver is in normal state and ready for accepting signals from controller.
AC	Power	AC110~220V (the optimal voltage is AC110V)
GND	Ground wire	Ground
U	Connect to the motor	Please refer to motor connections
V		
W		