

□ 56mm

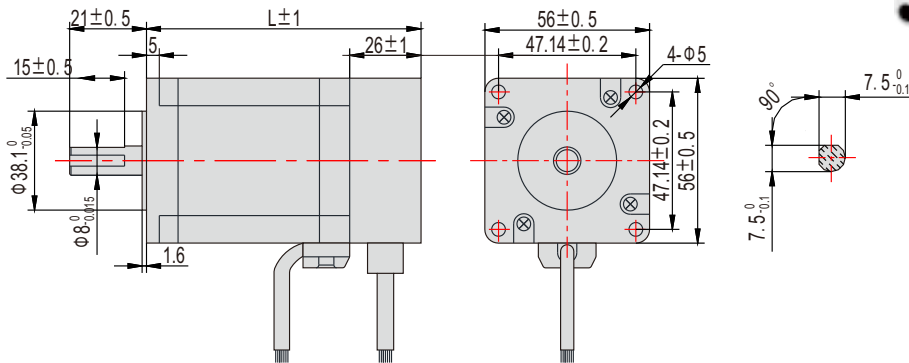

Dimension



Wiring Diagram

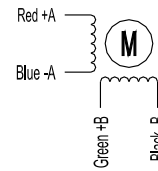

- ※ The above drawings are for dual shaft products while single shaft without dotted part.
- ※ Customized features are available, such as additional eccentric gear box, power off brake, encoder.
- ※ Spigot installation with front cover is a must when set up the motor, tolerance fiding should be taken into account, to secure the concentricity of output shaft and motor output.

Technical Parameters

Item	Specifications
Step Angle	1.8°
Step Angle Accuracy	±5%(full step,no load)
Resistance Accuracy	±10%
Inductance Accuracy	±20%
Temperature Rise	80°C Max (rated current,2 phase on)
Ambient Temperature	-20°C~+50°C
Insulation Resistance	100MΩ Min500VDC
Dielectric Strength	500V AC for one minute
Shaft Radial Force	0.02Max (450g load)
Axial Play	0.08Max (450g load)
Max Radial Force	75N (20mm from the flange)
Max Axial Force	15N

Technical Parameters

Stepper Motor Model		Stepper Drive Model	Current /phase	Resistance /phase	Inductance /phase	Holding Torque	Lead	Rotor Inertia	Weight	Lenth with encoder
Single shaft	Double shaft		A	Ω	mH	kg-cm		g-cm ²	Kg	L(mm)
YSD254-RA4-E	YSD254-RB4-E	SEB2M55	3	0.5	1.2	7	4	120	0.5	70
YSD255-RA4-E	YSD255-RB4-E		3	0.7	2.3	11	4	200	0.98	80
YSD258-RA4-E	YSD258-RB4-E		3	1	4	24	4	480	1.4	104